



New Tech Machinery

TSM - Tapered Slitting Machine OPERATION and MAINTENANCE MANUAL



U.S. PATENT PENDING

MANUFACTURED BY:

New Tech Machinery Corp.
1300 40th St
Denver, CO 80205-3311

Phone: 303-294-0538 or 800-574-1717
Fax: 303-294-9407
Email: sales@newtechmachinery.com
Website: www.newtechmachinery.com

TSM-MAN
7-16-2012

TABLE OF CONTENTS

SECTION	DESCRIPTION	PAGE
1	SPECIFICATIONS.....	2
2	PRECAUTIONS.....	3
3	MACHINE ORIENTATION.....	4
4	SETUP	5
5	CONTROLS	8
6	MAKING A TAPERED CUT	9
7	MAKING A STRAIGHT CUT	15
8	MAINTENANCE	16
9	TROUBLESHOOTING.....	21
10	ELECTRICAL SCHEMATIC	25

SECTION 1
TSM SPECIFICATIONS

Dimensions: Length - 84½" (2.15 m)
Width - 41½" (1.05 m)
Height - 45½" (1.16 m)
Weight - 550 lbs. (250 kg)

Electrical: Configuration 1 - 110VAC, 60 Hz, 11 Amps
Configuration 2 - 220VAC, 50 Hz, 6 Amps

Speed: 35.4 ft/min (10.8 m/min) Approximate at 60 Hz
29.5 ft/min (9.0 m/min) Approximate at 50 Hz

Capacity: Painted Steel - 30ga to 20ga (.3mm to .9mm)
Aluminum - .019" to .050" (.5mm to 1.3mm)
Copper - 16 oz. to 20 oz. ¾ Hard (.5mm to .7mm)

Maximum Material Width: 60" (1.52 m)
Maximum Cut Width: 30" (0.76 m)

SECTION 2
PRECAUTIONS

1. **Make sure the operator of the machine has read and understands this manual in its entirety before attempting to operate this equipment.**
2. **ALWAYS** keep covers, and guards mounted to machine during operation
3. **OBSERVE and OBEY** all safety and warning signs affixed to the machine.
4. **DO NOT** stare directly into the laser beam as permanent eye damage can result. The laser on your Tapered Slitting Machine is a Class IIIA laser product (similar to a laser pointer or laser level). Direct eye exposure must be avoided.
5. **DO NOT** wear loose clothing, jewelry etc. that could become entangled in the moving parts of the machine when operating.
6. **STOP THE MACHINE** and disconnect the power before attempting to make any adjustments, perform any maintenance or changeover procedures.
7. **AVOID** storing the machine outdoors for long periods of time. Cover with a tarp but provide good ventilation to prevent condensation and rust. If the machine will sit unused for an extended period coat the slitting knives with a thin layer of oil to prevent rust. Clean the knives off before using the machine again.

SECTION 3
MACHINE ORIENTATION

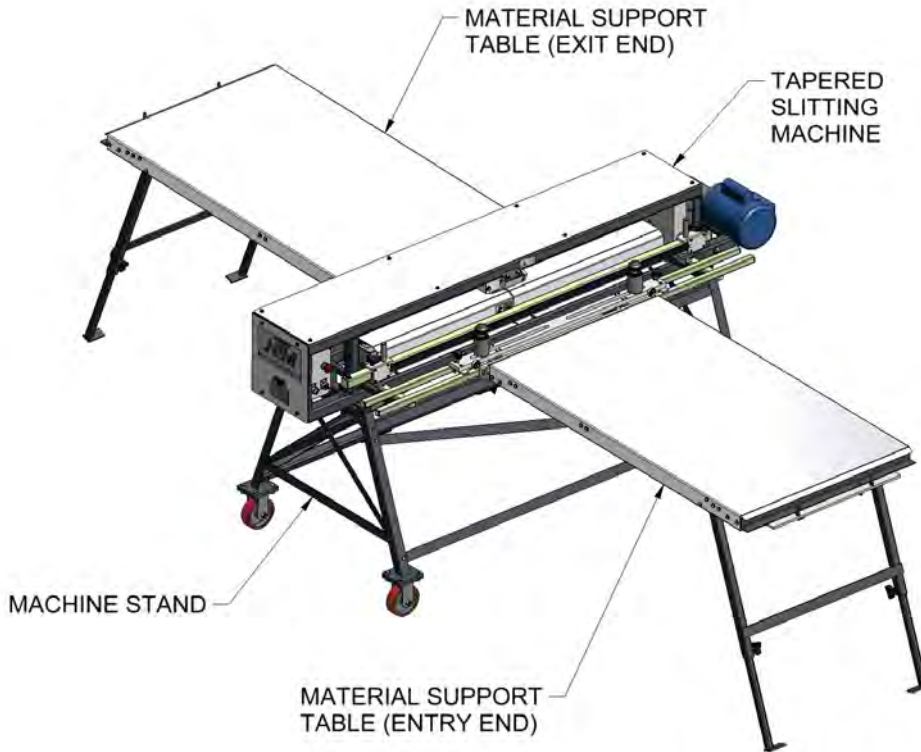

Fig. 3-1. Machine Orientation

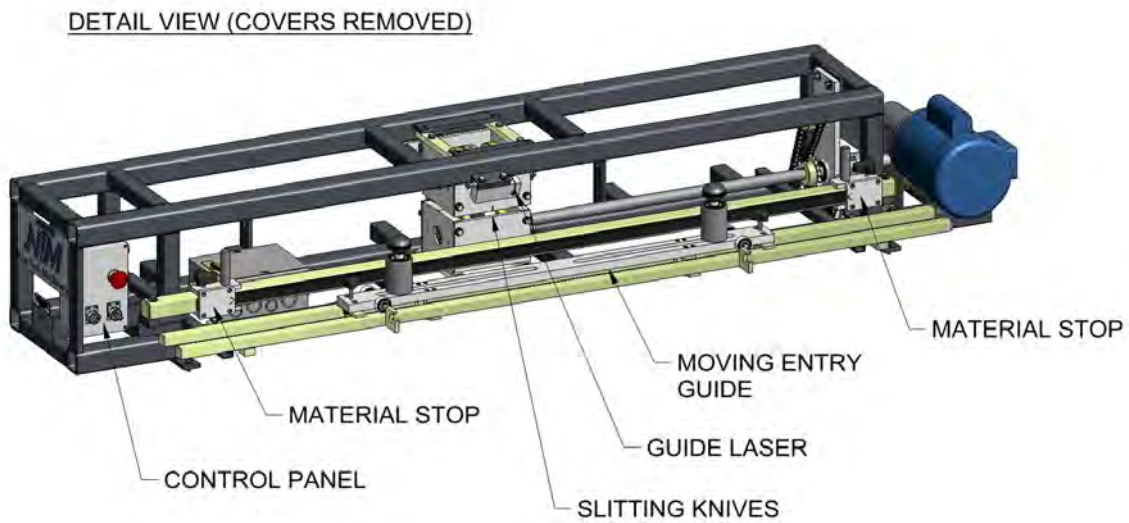

Fig. 3-2. Machine Orientation Detail

SECTION 4
MATERIAL SUPPORT TABLE SETUP

1. Unfold the table legs.
2. Insert the table mounting pins into the notches on the machine, as shown in **Fig. 4-1**.
3. Adjust the legs until the ends of the tables furthest from the machine are $38\frac{3}{4}$ " above the floor, as shown in **Fig. 4-2**. Note: The table on the exit end of the machine will not be level.

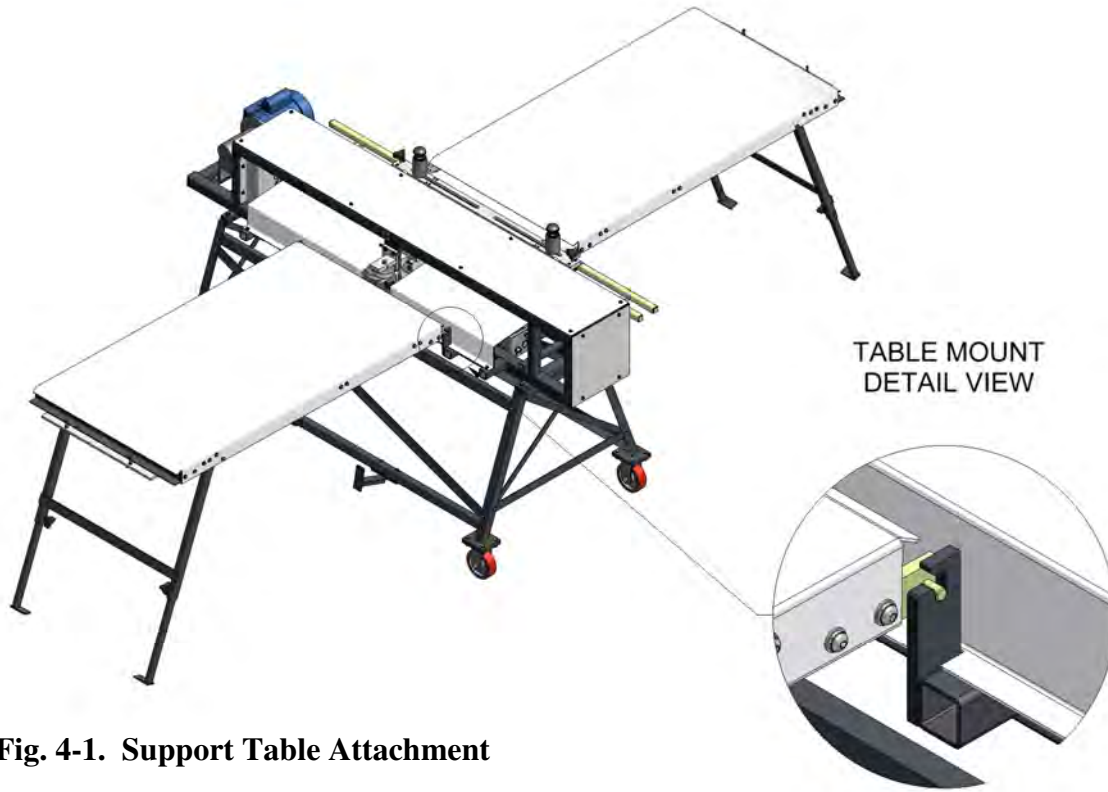

Fig. 4-1. Support Table Attachment

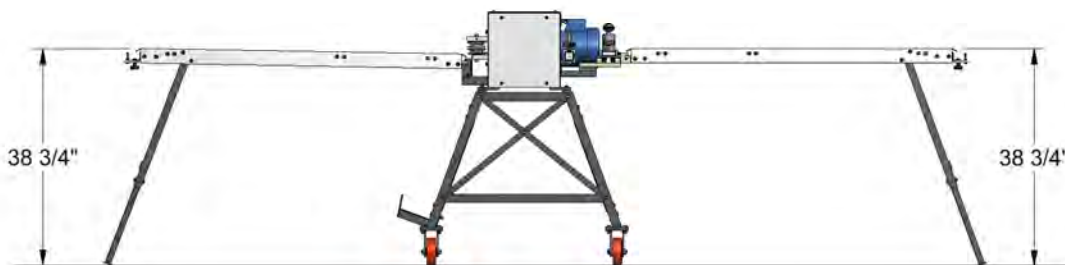

Fig. 4-2. Support Table Height

SECTION 4
MATERIAL SUPPORT TABLE SETUP

ATTACHING ADDITIONAL SUPPORT TABLES

Standard 10' long New Tech Machinery Run Out Tables can be added to the machine for slitting longer panels.

1. If necessary, adjust the slotted mounting plates to position the Run Out Tables where they will best be able to support the panel being slit. Loosen the knobs, slide the plate to its new position, and tighten the knobs back down again, see **Fig. 4-3**.
2. Mount the Run Out Tables by lining up the clearance holes on the tables to the bolts on the slotted mounting plate and dropping the table into place, see **Fig. 4-4**. Adjust the lengths of the legs until the Run Out Tables are level.
3. Additional Run Out Tables can be added to support any length of panel.

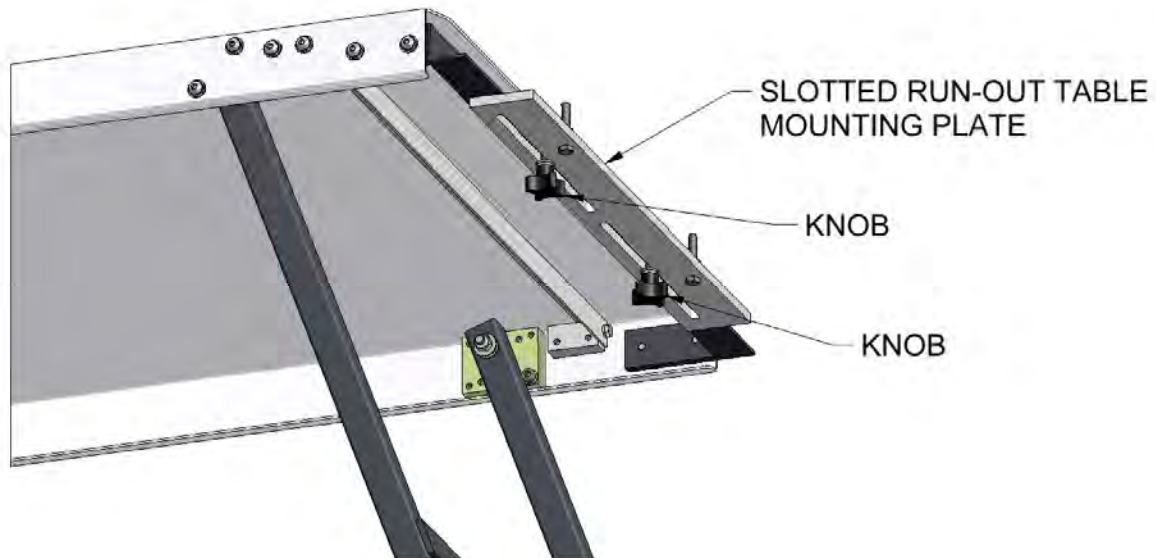

Fig. 4-3. Left/Right Run Out Table Adjustment

SECTION 4
MATERIAL SUPPORT TABLE SETUP



Fig. 4-4. Run Out Table Attachment

SECTION 5 CONTROLS

1. CONTROL PANEL (Fig. 5-1)

A. FORWARD-REVERSE Switch

This selector switch controls the direction of movement of the material through the machine. Select forward for normal operation, and select reverse only if a problem is encountered and the panel needs to be backed up or removed.

B. JOG-RUN Switch

This selector switch allows you to run the machine continuously, or jog material through the machine. When making a tapered cut it is recommended that you use Jog mode as this allows better control of the panel as it moves through the machine. Run mode can be used when making a straight cut.

NOTE: For operator safety, your machine will only run in Jog mode when the Forward-Reverse switch is set to Reverse.

C. EMERGENCY STOP / POWER ON Button

Function #1 - Power On

Pulling this button OUT will turn on the machine and activate the laser (although the motor won't start until the foot pedal is pressed, see below).

Function #2 - Emergency Stop & Power Off

Pushing this button IN will stop the motor and turn off the laser.

D. FOOT PEDAL SWITCH (not shown in figure)

Depressing the foot pedal switch will activate the motor and the slitting knives. If the machine is in run mode, the motor will continue to run until either the Emergency Stop button is pressed or the Jog-Run switch is moved to Jog. If the machine is in jog mode, the motor and slitting knives will shut off once the pedal is released.

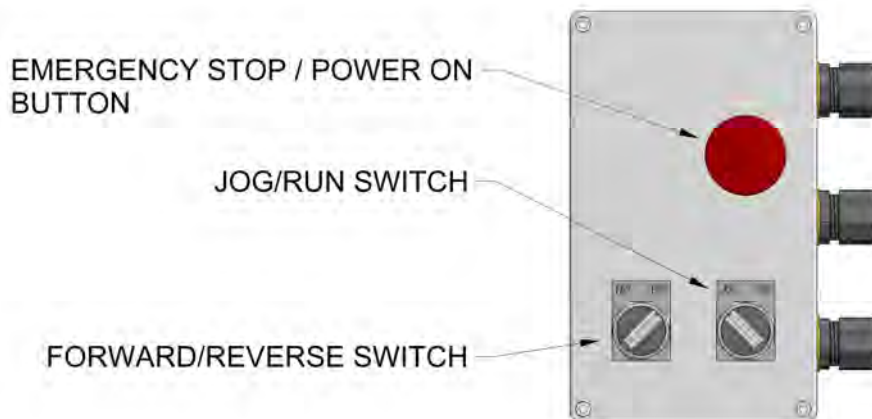

Fig. 5-1. Control Panel

SECTION 6
MAKING A TAPERED CUT

1. **MARKING THE PANEL**

If the slitter is going to be used to make a tapered cut for the purpose of forming a tapered roof panel then follow the steps below:

A. It is recommended that one of the profile legs be formed on a standard roof panel machine (i.e. an NTM SSQ, SSH, or SSR roof panel machine) before the panel is slit to a taper. To do this, either move one half of the forming rollers out of the way or remove them altogether. Next, move the shear dies on the un-formed side of the panel away from the panel so it doesn't crash into it as it exits the machine. Do not remove the shear dies as they are needed to guide the shear blade into the lower shear dies. Once this is done, form your roof panels at whatever length is required.

B. Once you have a panel with one leg formed on it, the next step is to calculate the width at each end that it needs to be cut to. The dimension at each end will be the sum of the required finished width plus the material usage that will be needed to form the second leg of the panel. See **Fig. 6-1** for material usages.

For example: Let's say you're making a tapered roof panel in the SS150 profile, and the finished width (Dimension A in **Fig. 6-1**) needs to be 6" at the narrow end and 18" at the wide end. The female side has already been formed. In this example, the width that it needs to be cut at would be 7 3/4" at the narrow end (6" finished width + 1 3/4" material usage to form the male leg) and 19 3/4" at the wide end (18" finished width + 1 3/4" material usage). See **Fig. 6-2**.

C. Mark the panel at the dimensions found in step B and snap a chalk line between them, see **Fig. 6-2**.

SECTION 6
MAKING A TAPERED CUT

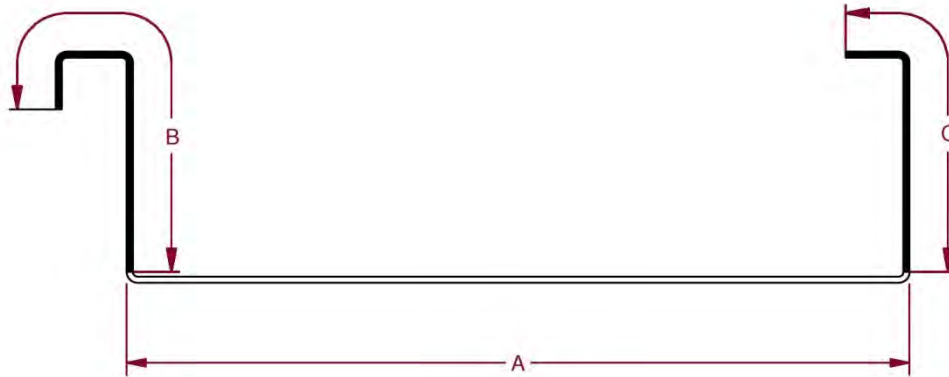

Narrowest panels that can be formed on the TPM (**Dimension A**)

	Male-Male	Female-Female	Male-Female (M 1st)	Male-Female (F 1st)
SS100	5 7/16"	4 1/8"	4 5/16"	5"
SS150	5 7/16"	4 1/16"	4 1/4"	5 1/16"
SS200/210A	5"	4"	4 3/4"	**4 1/2"
SS450/SL	5"	4 7/8"	4"	5 1/8"

** Not Recommended – The 200/210A should be run with the Male leg first

Material Usage (**Dimension B & C**)

	Female (Dimension B)	Male (Dimension C)	Total
SS100	1 3/4"	1 1/4"	3"
SS150	2 1/4"	1 3/4"	4"
SS200	3 1/4"	2 9/16"	5 13/16"
SS210A	3 1/4"	3 1/8"	6 1/8"
SS450	3 1/16"	15/16"	4"
SS450SL	3 1/16"	1	4 1/16"

Coil Width Requirements:

Standard Male-Female panel = A + B + C

Male-Male starter panel = A + C + C

Female-Female finishing panel = A + B + B

Fig. 6-1. Material Usage Chart.

SECTION 6
MAKING A TAPERED CUT

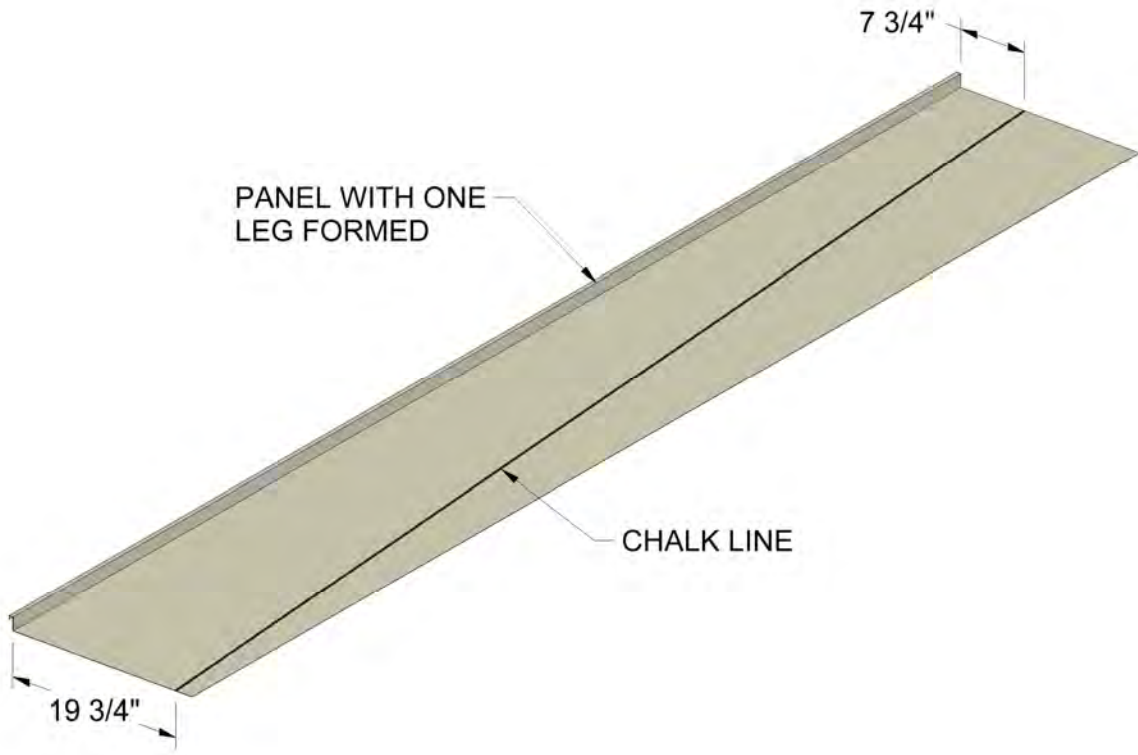

Fig. 6-2. Panel Marking Example.

SECTION 6
MAKING A TAPERED CUT

2. **LOADING THE PANEL INTO THE MACHINE**

A. Once the cut line has been marked on the panel, lay it on the entry support table(s) and line up the chalk line with the indicator mark near the slitting knives, see **Fig 6-3**. Push the panel into the machine until it contacts the slitting knives.

B. Turn on the laser by pulling out the emergency stop button. Rotate the panel until the chalk line is directly under the laser dot, see **Fig 6-3**. Check that the chalk line is still lined up with the indicator mark and adjust if necessary.

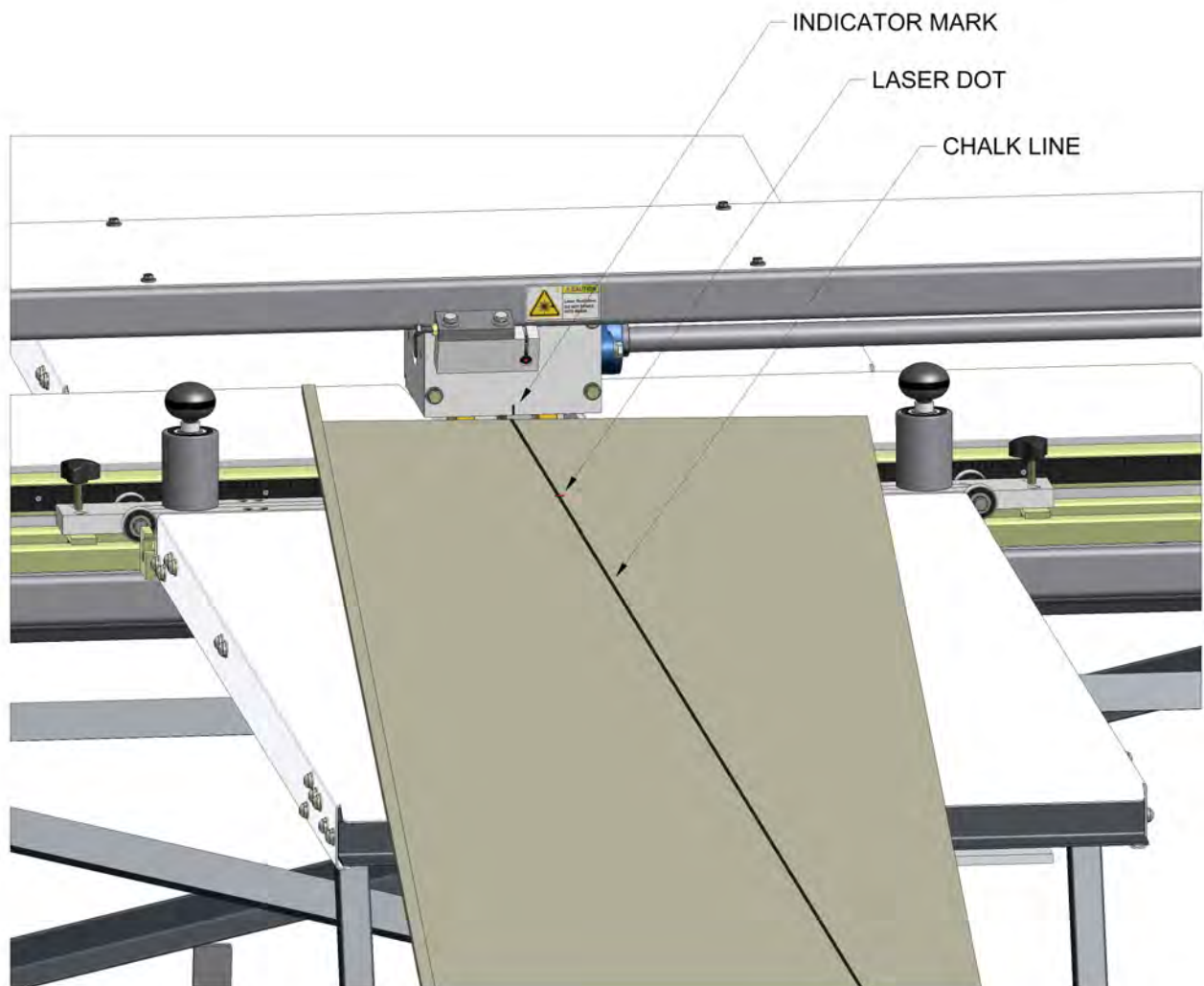

Fig. 6-3. Aligning The Panel Before Cutting

SECTION 6
MAKING A TAPERED CUT

3. **ADJUSTING THE MOVING ENTRY GUIDE**

Loosen the knobs on top of the Moving Entry Guide rollers, push the rollers up against the sides of the panel, and tighten the knobs back down again, see **Fig. 6-4**.

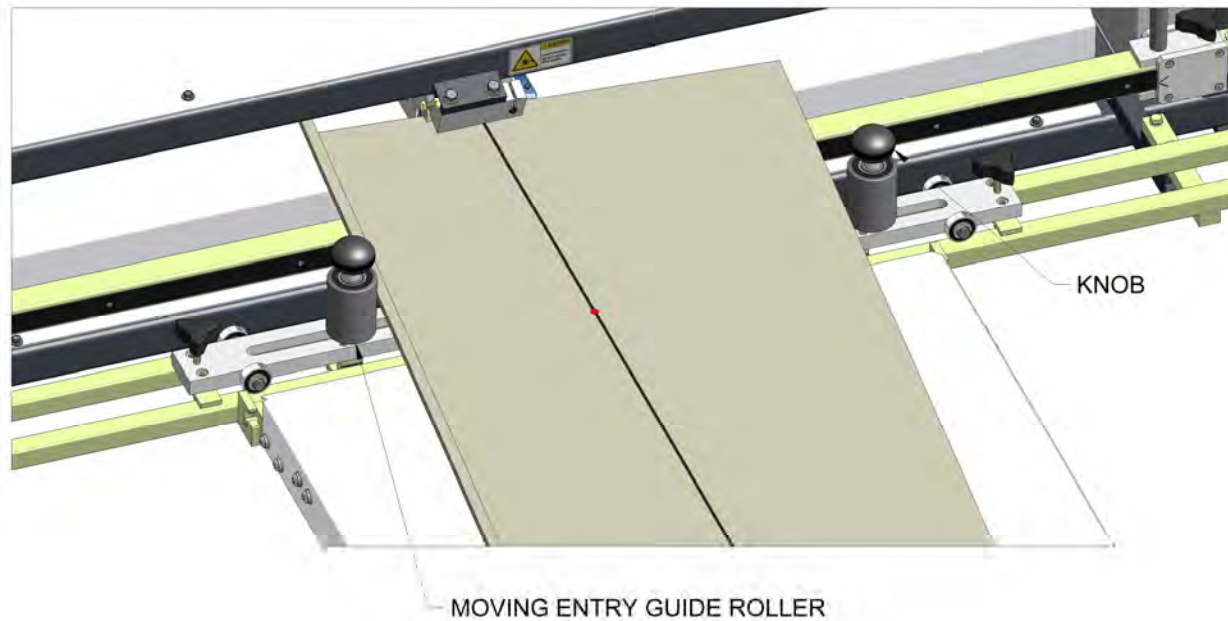

Fig. 6-4. Adjusting The Moving Entry Guide

4. **CUTTING THE PANEL**

With the machine in Jog mode, use the foot pedal to slowly advance the material while watching the laser dot. Use the Moving Entry Guide to steer the panel left or right to keep the chalk line directly under the laser dot. (**Note:** On long panels, better results can be obtained by gripping the panel further away from the machine and pushing it left or right, instead of using the Moving Entry Guide.) Once the material engages the Exit Rollers (**Fig. 6-5**) the machine will cut fairly straight on its own, but you will still need to make small adjustments to keep the laser dot in line with the chalk line.

SECTION 6
MAKING A TAPERED CUT

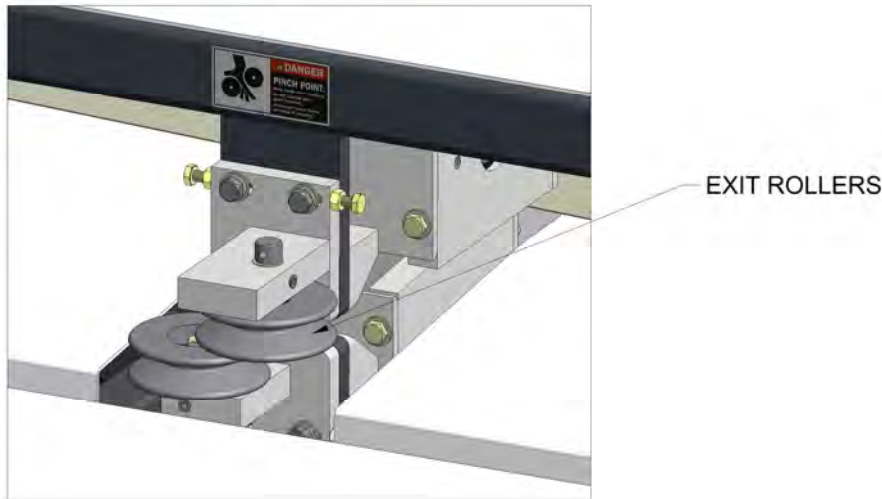

Fig. 6-5. Exit Rollers

5. **ATTACHING THE RUN OUT TABLE HELPERS**

To prevent the panel from getting caught on the run out table conveyor rollers as it exits the machine, attach the Run Out Table Helpers as shown in **Fig. 6-6**. Loosen the knobs, slide the helpers over the leading edge of the material, and tighten the knobs back down again.

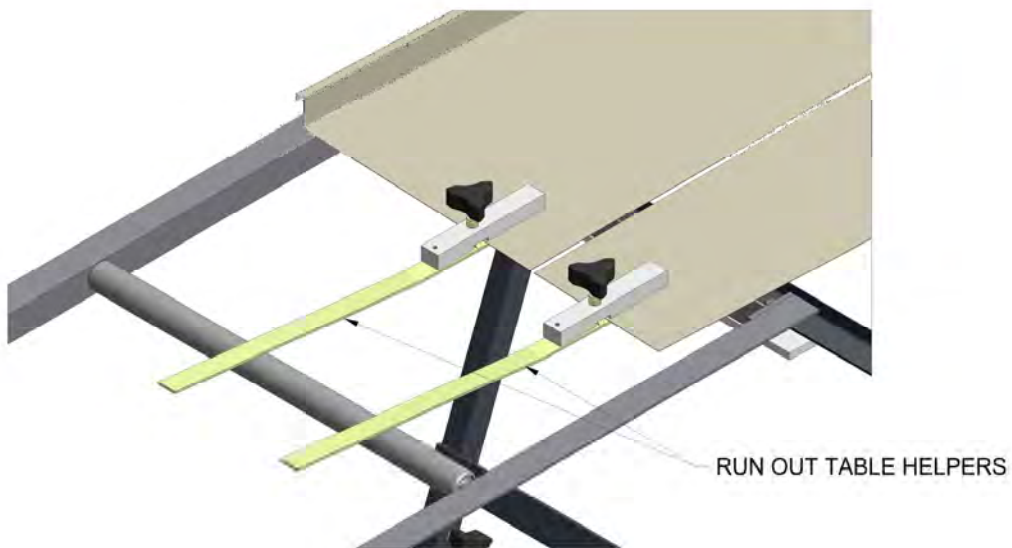

Fig. 6-6. Run Out Table Helpers

SECTION 7
MAKING A STRAIGHT CUT

1. Mark a two foot long straight line on the leading edge of the panel where the cut needs to be made, see **Fig 7-1**.
2. Lay the panel on the entry-side support table and line up the mark on the panel to the indicator mark near the slitting knives and laser dot, as shown in **Fig. 6-3, Page 12**.
3. Tighten the lock-down knobs on the Moving Entry Guide to hold it in place. Loosen the roller knobs, move the rollers up against the sides of the panel, and tighten the roller knobs back down again, see **Fig 7-1**.
4. Loosen the knobs on the Fixed Entry Guide, slide the material stops against the sides of the panel, and tighten the knobs back down again, see **Fig 7-1**.
5. Cut the panel. To prevent the panel from getting caught on the run out table conveyor rollers as it exits the machine, attach the Run Out Table Helpers as shown in **Fig. 6-6, Page 14**. Any additional panels can be cut without needing to mark or measure by feeding them through the entry guides.

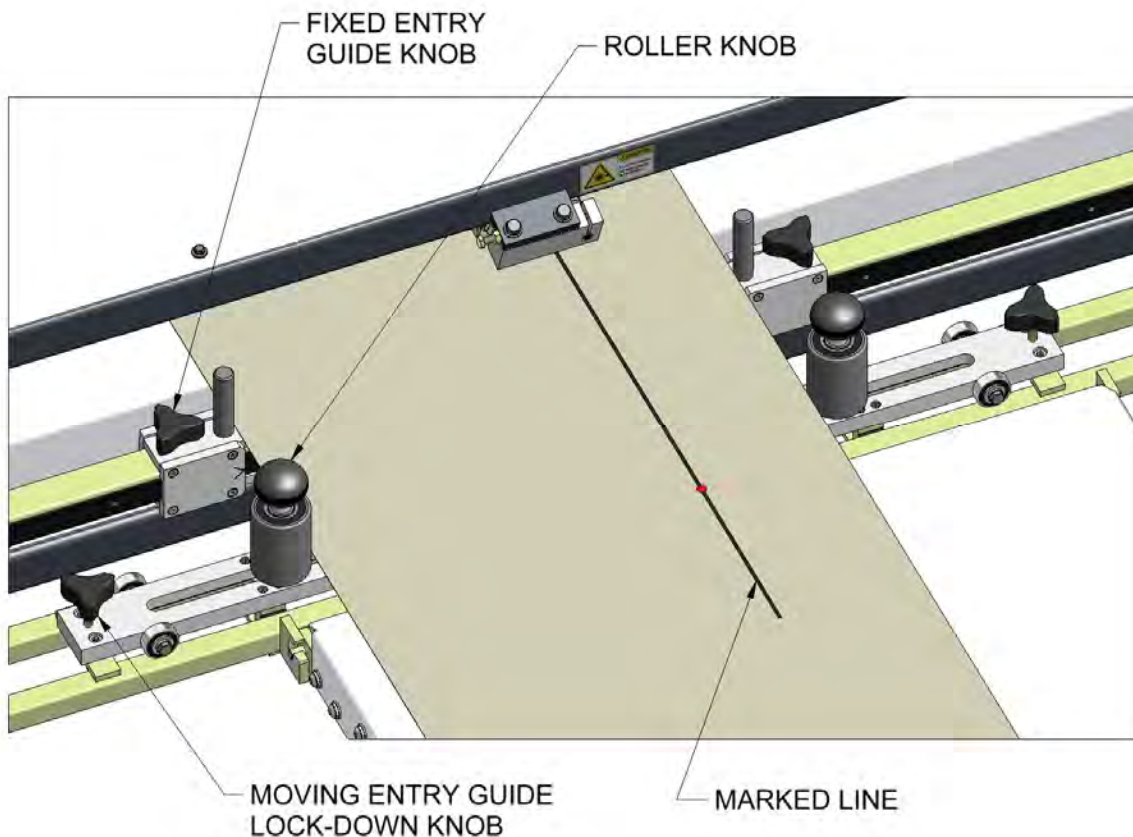

Fig. 7-1 Setting Up For A Straight Cut

SECTION 8
MAINTENANCE

- Lubricate the chain a minimum of every 40 hours of operation. It is preferable to use a dry motorcycle chain lube or equivalent.
- Keep chains properly tensioned. This will add to the life of the chains and sprockets. The chains should be just snug. An over-tightened chain is just as bad for the machine as a loose chain. To adjust tension first unplug the machine, then loosen the bolt on the chain tensioning sprocket, reposition the sprocket as needed, and retighten the bolt, see **Fig. 8-1**.

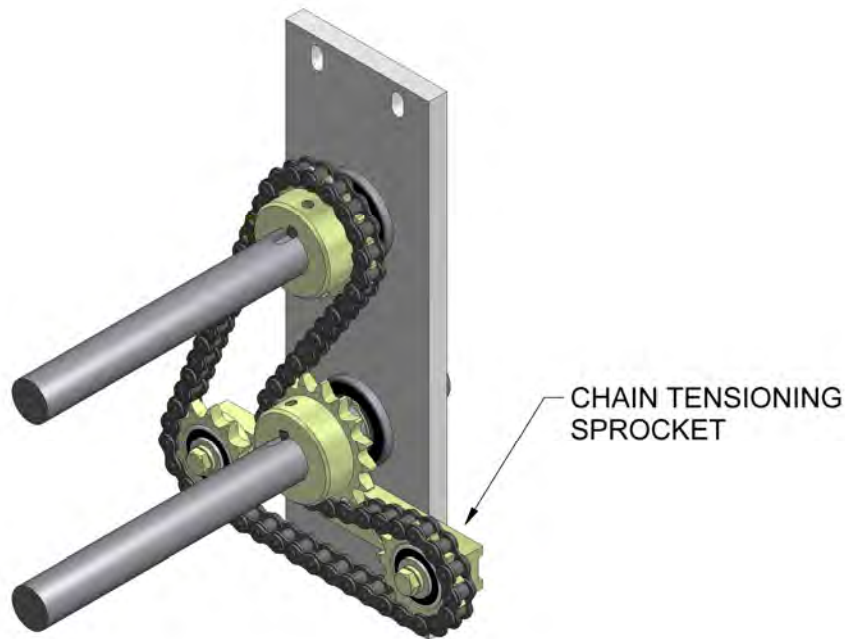

Fig. 8-1. Chain Tensioning Sprocket

- The gearbox is lubricated for life and doesn't require maintenance.
- Although the slitting knives are made from high quality hardened steel they will still become dull with ordinary use. When this happens they can be flipped around to make use of the other edge. Once both edges are dull, the knives will need to be ground down to restore the cutting edge at a qualified machine shop, or they can be returned to New Tech Machinery for sharpening. Follow the steps below to remove and reinstall the slitting knives.

SECTION 8
MAINTENANCE
SLITTER KNIFE REMOVAL AND REINSTALLATION

1. Disconnect power to the machine then remove the two covers shown in **Fig. 8-2**.

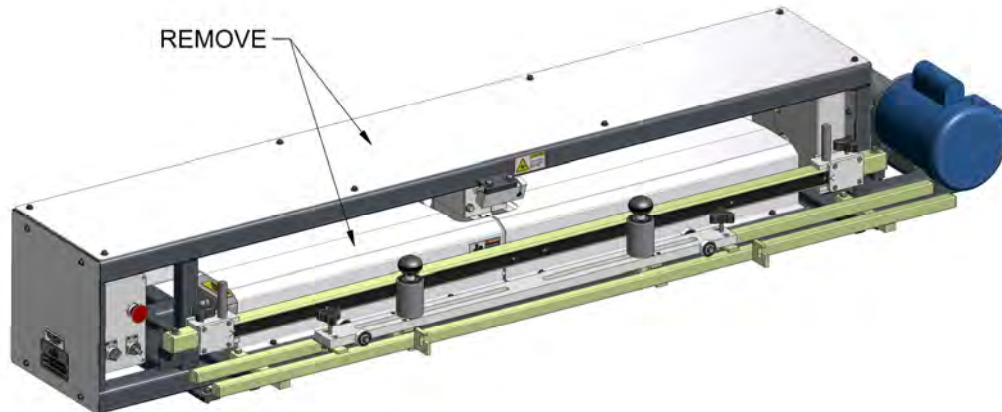

Fig. 8-2. Slitter Knife Removal Step 1

2. Remove the four bolts shown in **Fig 8-3**, and loosen the two bolts shown in **Fig 8-3**.

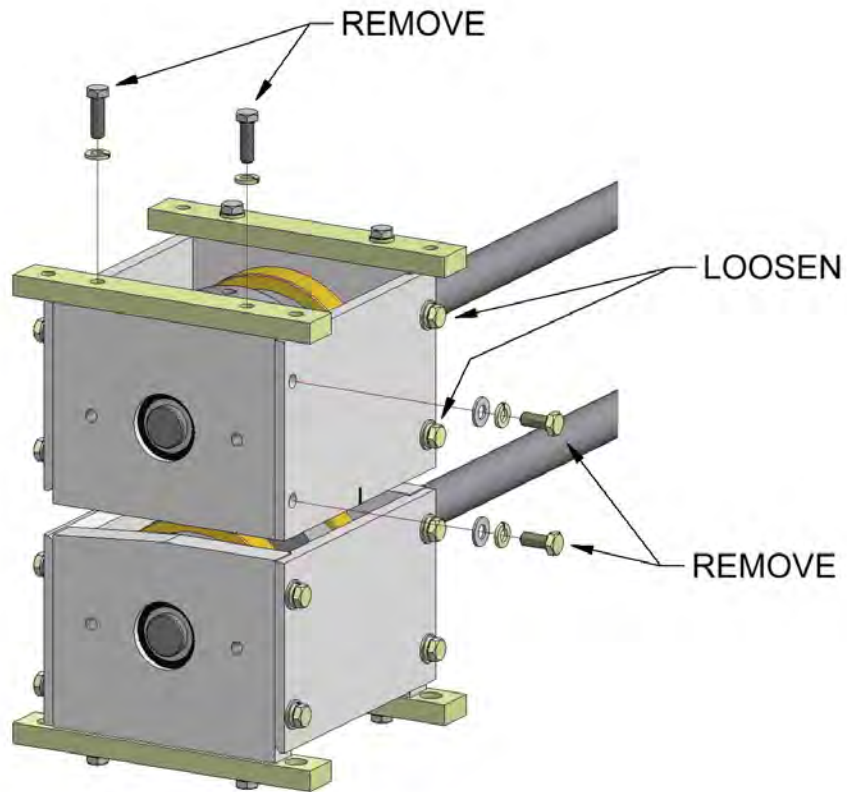

Fig. 8-3. Slitter Knife Removal Step 2

SECTION 8
MAINTENANCE
SLITTER KNIFE REMOVAL AND REINSTALLATION

3. Remove the two bolts shown in **Fig. 8-4**, and loosen the two bolts shown in **Fig. 8-4**.

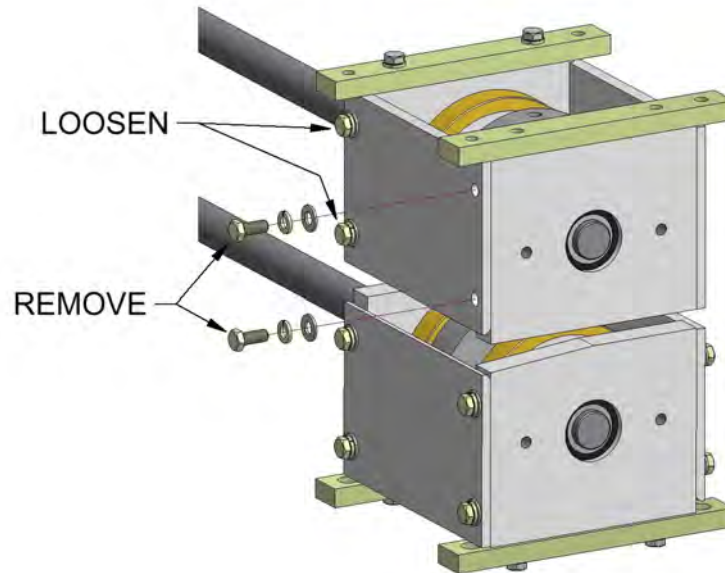

Fig. 8-4. Slitter Knife Removal Step 3

4. Remove the bearing plate, loosen the set screws on the left upper drive roller and remove it. Loosen the set screws on the slitter knife, and carefully slide the slitter knife off of the shaft. **Caution:** The edges of the slitter knife are sharp.

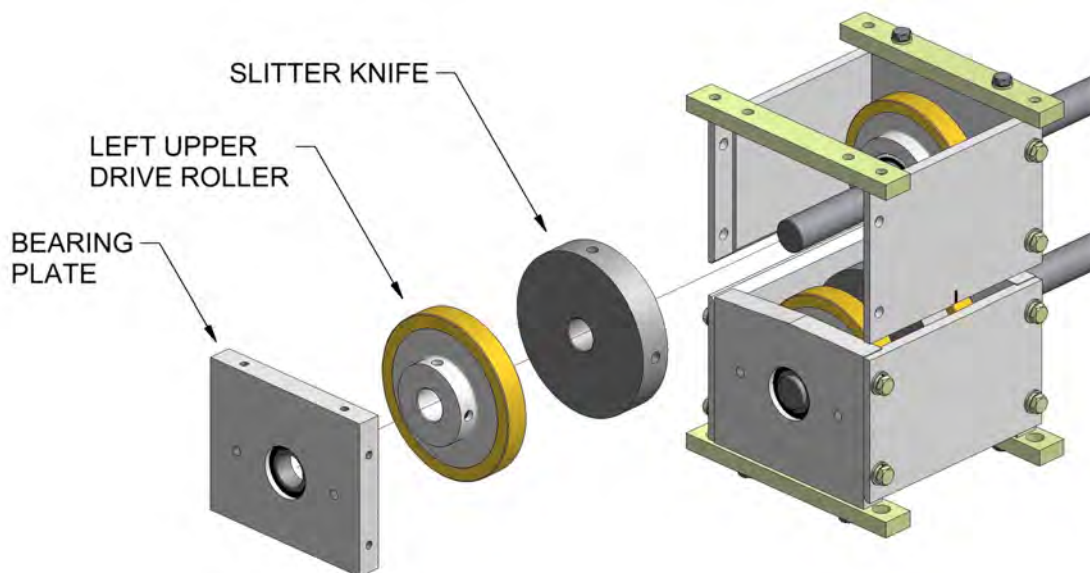

Fig. 8-5. Slitter Knife Removal Step 4

SECTION 8
MAINTENANCE
SLITTER KNIFE REMOVAL AND REINSTALLATION

5. Remove the four bolts shown in **Fig 8-6**, and loosen the two bolts shown in **Fig 8-6**.

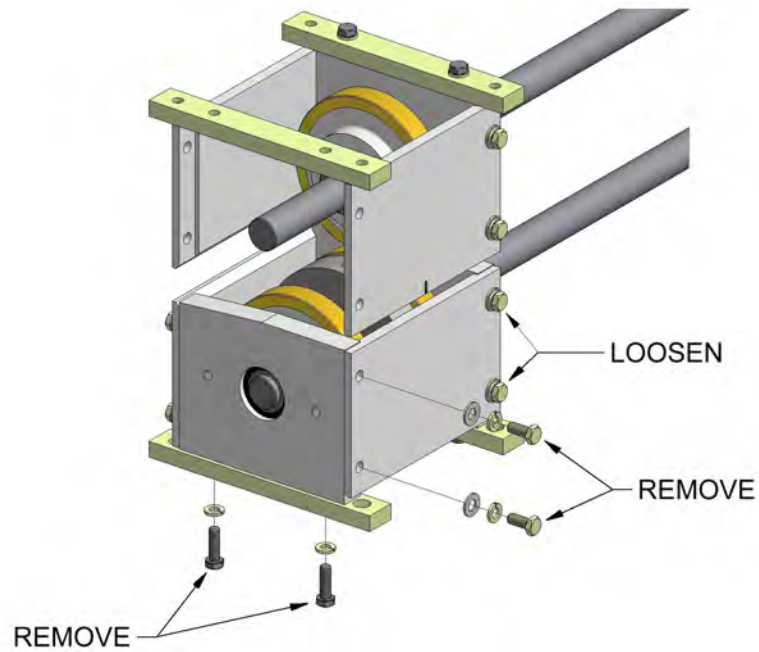

Fig. 8-6. Slitter Knife Removal Step 5

6. Remove the two bolts shown in **Fig. 8-7**, and loosen the two bolts shown in **Fig. 8-7**.

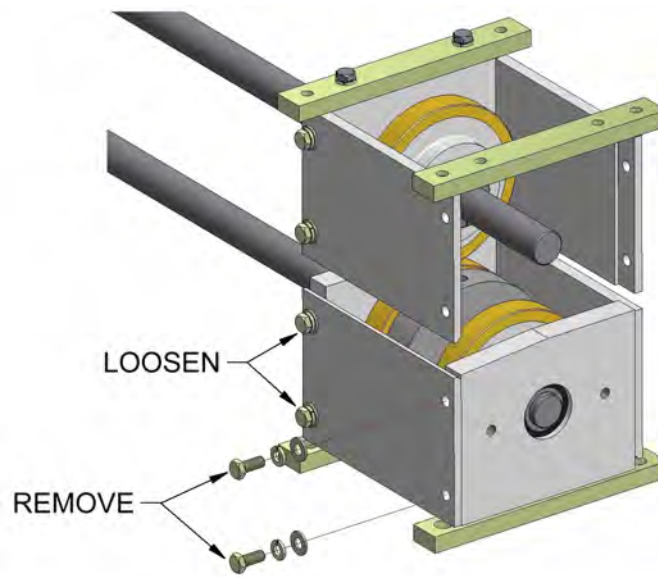

Fig. 8-7. Slitter Knife Removal Step 6

SECTION 8
MAINTENANCE
SLITTER KNIFE REMOVAL AND REINSTALLATION

7. Remove the bearing plate, spacers, and left lower drive roller. Loosen the set screws on the slitter knife, and carefully slide the slitter knife off of the shaft. **Caution:** The edges of the slitter knife are sharp.

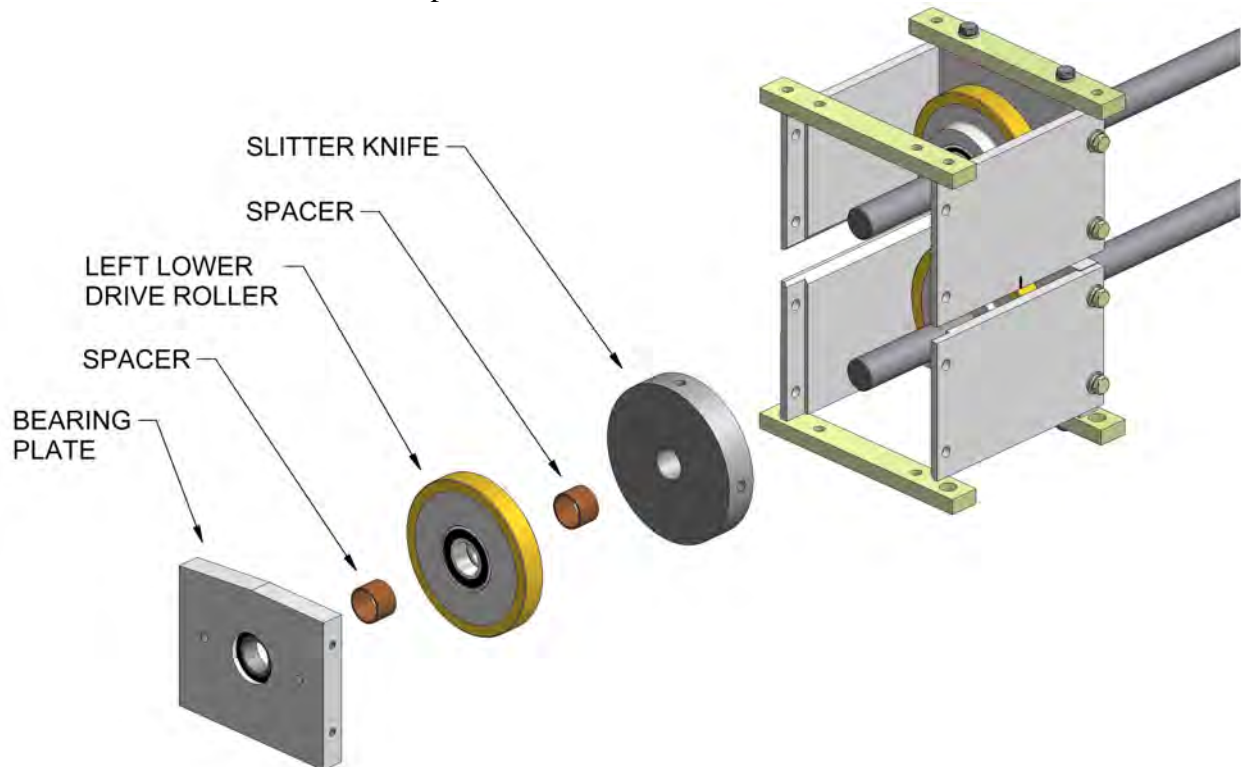

Fig. 8-8. Slitter Knife Removal Step 7

8. To reinstall the slitter knives, reverse the steps above with the following additions:
- Push the bearing plates securely up against the shoulders of the aluminum plates they mount to while tightening the bolts.
 - The lower slitter knife should be pulled tight against the spacer before tightening the set screws. This will position it correctly in the machine. Note: the bearing plate must already be tightened down before doing this, see previous step.
 - The upper slitter knife should be pushed tight against the lower slitter knife before tightening its screws. There should be no gap between the two knives.

SECTION 9
TROUBLESHOOTING

1. **PROBLEM:** Excessive force is needed to keep the chalk line in line with the laser dot.

SOLUTION: Adjust the Exit Roller assembly by following the steps below. Refer to **Fig. 9-1**.

- 1.1 Remove the panel from the machine and disconnect the power.
- 1.2 Loosen the four bolts (A) approximately one-quarter turn.
- 1.3 Loosen the four jam nuts (B) being careful not to turn the adjustment screws.

If you are having to pull the panel hard to the left (towards the control panel) as the machine is running then follow Step 1.4A below. If you're having to push the panel hard to the right (away from the control panel) then follow Step 1.4B.

1.4A By hand, loosen the two adjustment bolts (C) approximately two turns. With a wrench, tighten the two adjustment bolts (D) about one-quarter turn.

1.4B By hand, loosen the two adjustment bolts (D) approximately two turns. With a wrench, tighten the two adjustment bolts (C) about one-quarter turn.

- 1.5 Tighten the four bolts (A).
- 1.6 By hand, tighten the four adjustment screws (C&D) until they stop.
- 1.7 Tighten the four jam nuts (B).
- 1.8 If the problem remains continue to make small adjustments using the steps above.

SECTION 9
TROUBLESHOOTING

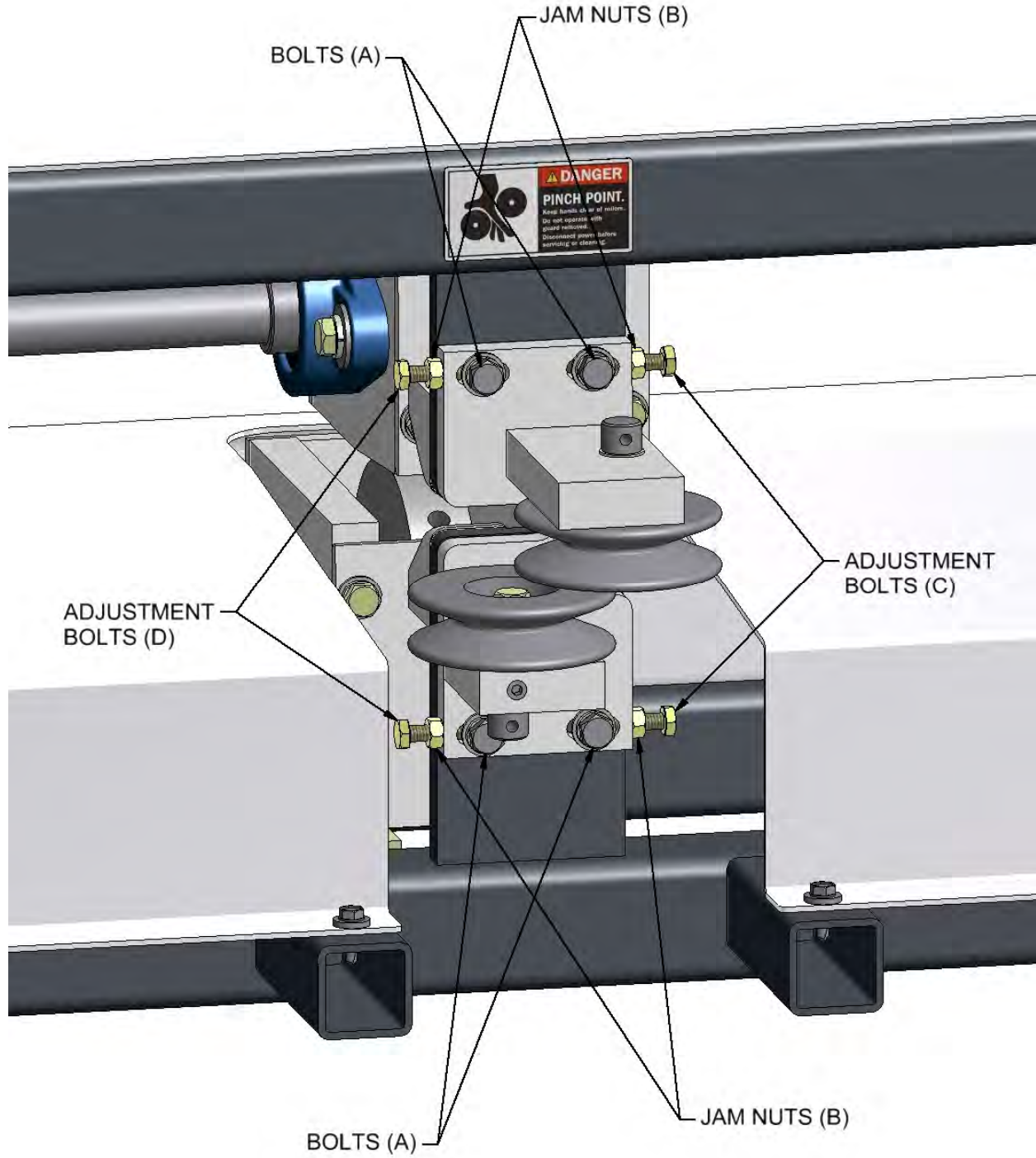

Fig. 9-1. Adjusting the Exit Roller Assembly

SECTION 9
TROUBLESHOOTING

2. **PROBLEM:** The chalk line is in line with the laser dot but the cut is not in line with the chalk line.

SOLUTION: Adjust the laser by following the steps below. Refer to **Fig. 9-2**.

2.1 Remove the panel from the machine and move the foot pedal to a location where it can't be accidentally stepped on.

2.2 Hold a two-foot long straight edge against the lower slitter knife as shown in **Fig. 9-2**. Make sure that the straight edge is flush against the knife, with no gaps between them.

2.3 The laser dot should be centered on the edge of the straight edge, see **Fig. 9-2**. If it isn't, then loosen the two bolts (A) and the jam nut (B). While holding the aluminum laser mount block against the adjustment screw (C), turn the adjustment screw until the laser dot is lined up with the edge of the straight edge. Retighten the bolts (A) and the jam nut (B).

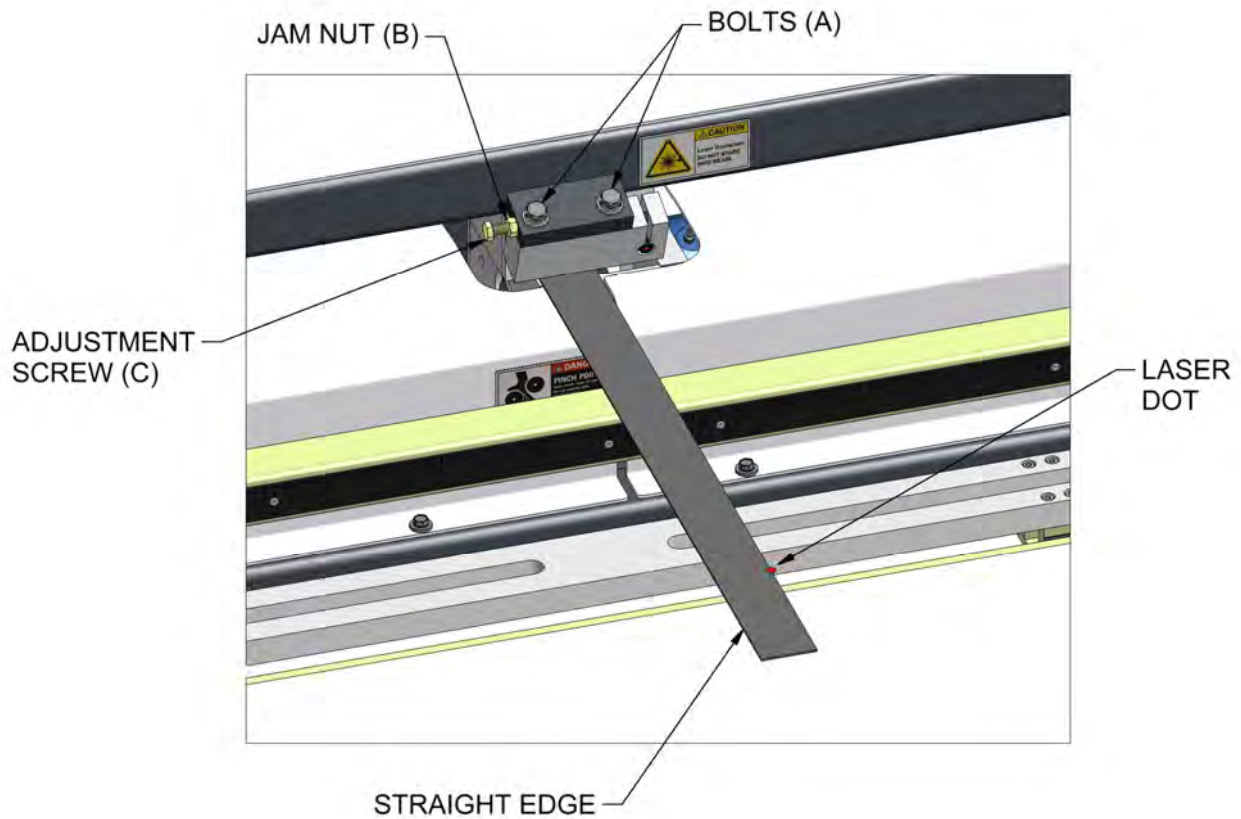

Fig. 9-2. Adjusting The Laser

SECTION 9
TROUBLESHOOTING

3. PROBLEM: There is a burr on one or both of the cut edges.

SOLUTION: Move the knives closer together by following the steps below.

3.1 Remove the top cover.

3.2 With the machine in Jog mode use the foot pedal to carefully advance the machine until one of the set screws is visible on the upper splitter knife. **CAUTION:** Keep hands and clothes away from the knives! Turn off the power and loosen the set screw.

3.3 Turn the machine back on and repeat the above step to loosen the second set screw on the upper knife.

3.4 Push the upper knife tight against the lower knife, retighten the set screws, and replace the top cover.

4. PROBLEM: The machine will not turn on.

SOLUTION: Check the fuse and replace if necessary. See **Fig. 9-3** for fuse location.

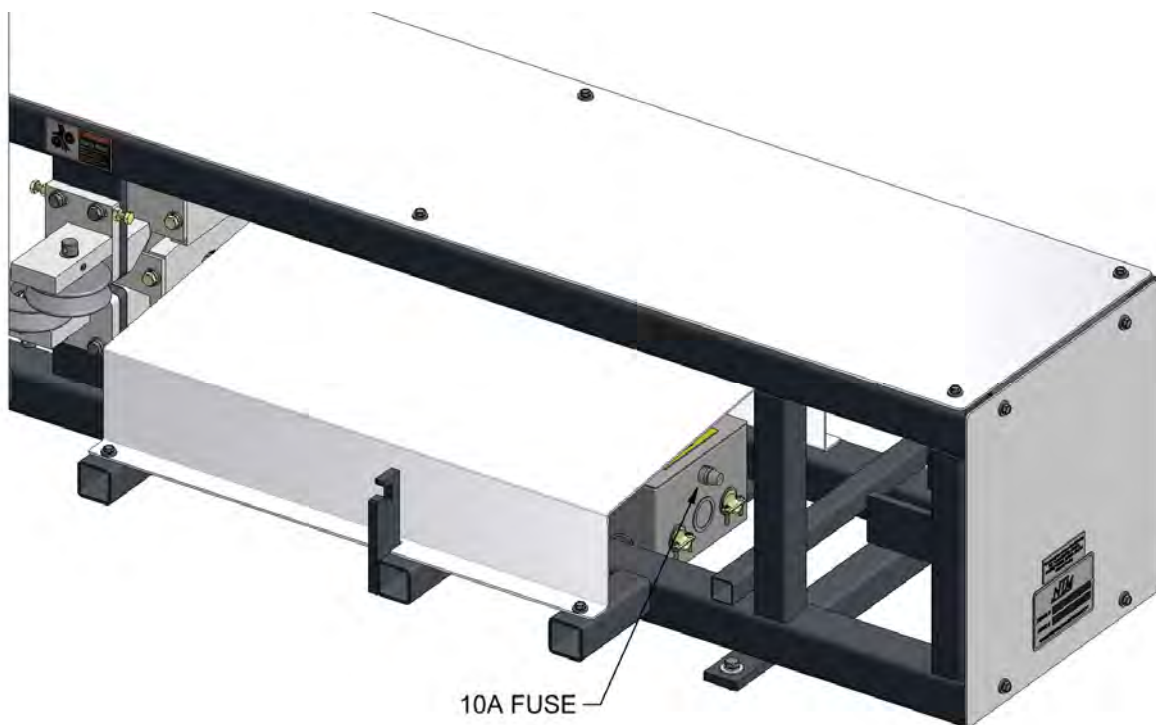

Fig. 9-3. Fuse Location

SECTION 10
ELECTRICAL SCHEMATIC

